

Content

Inhalt
Contenu
Inhoud

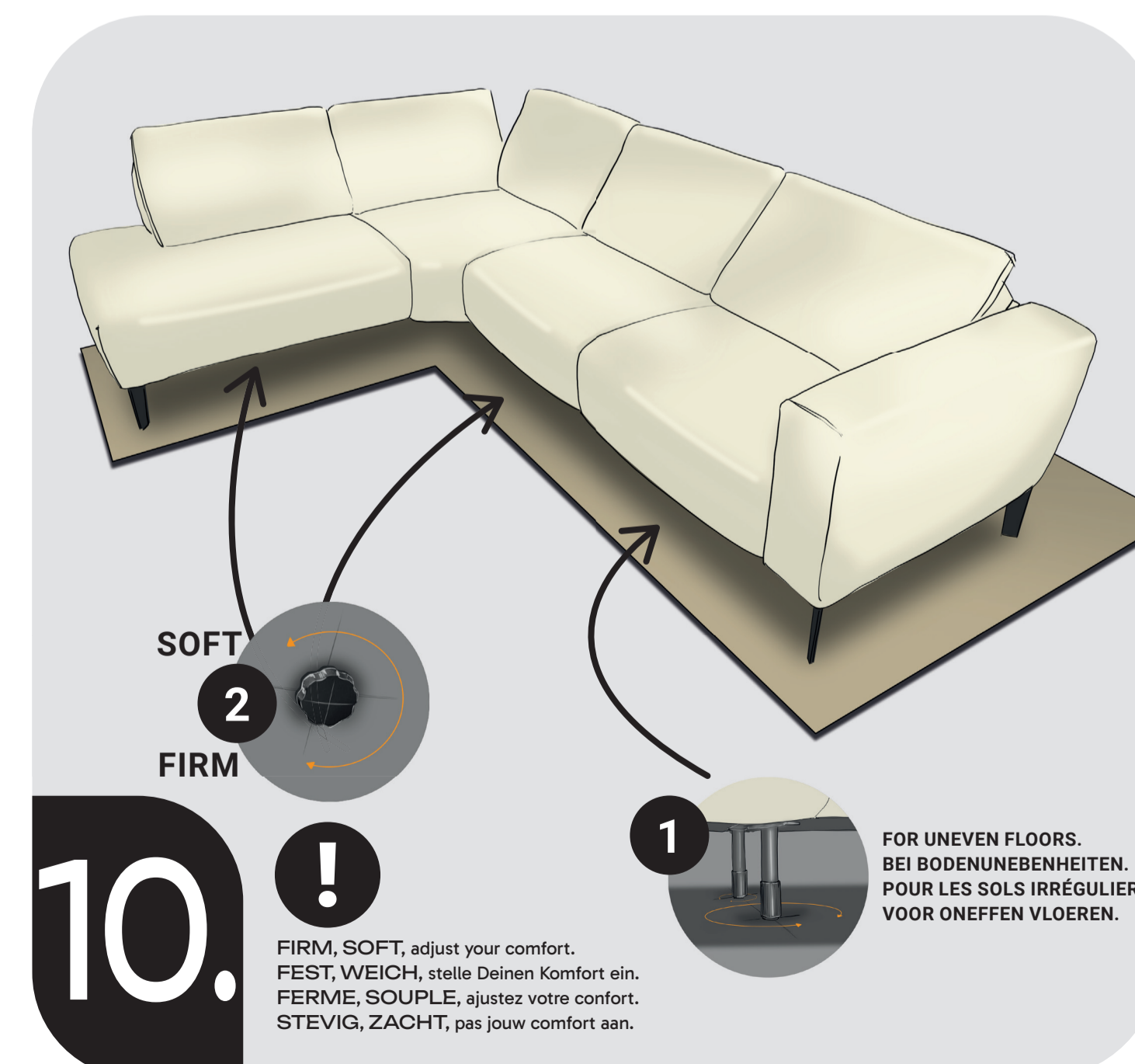

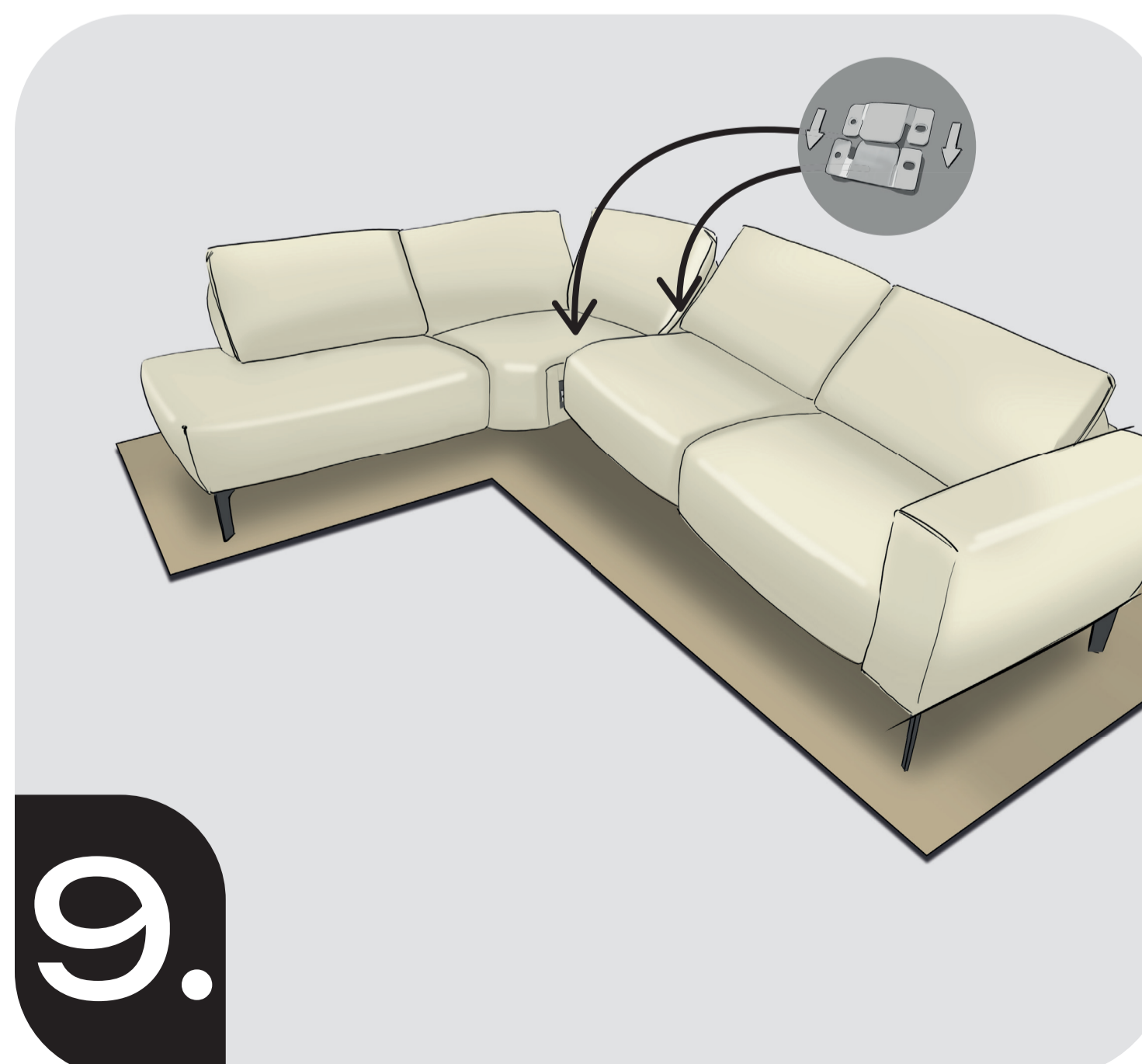
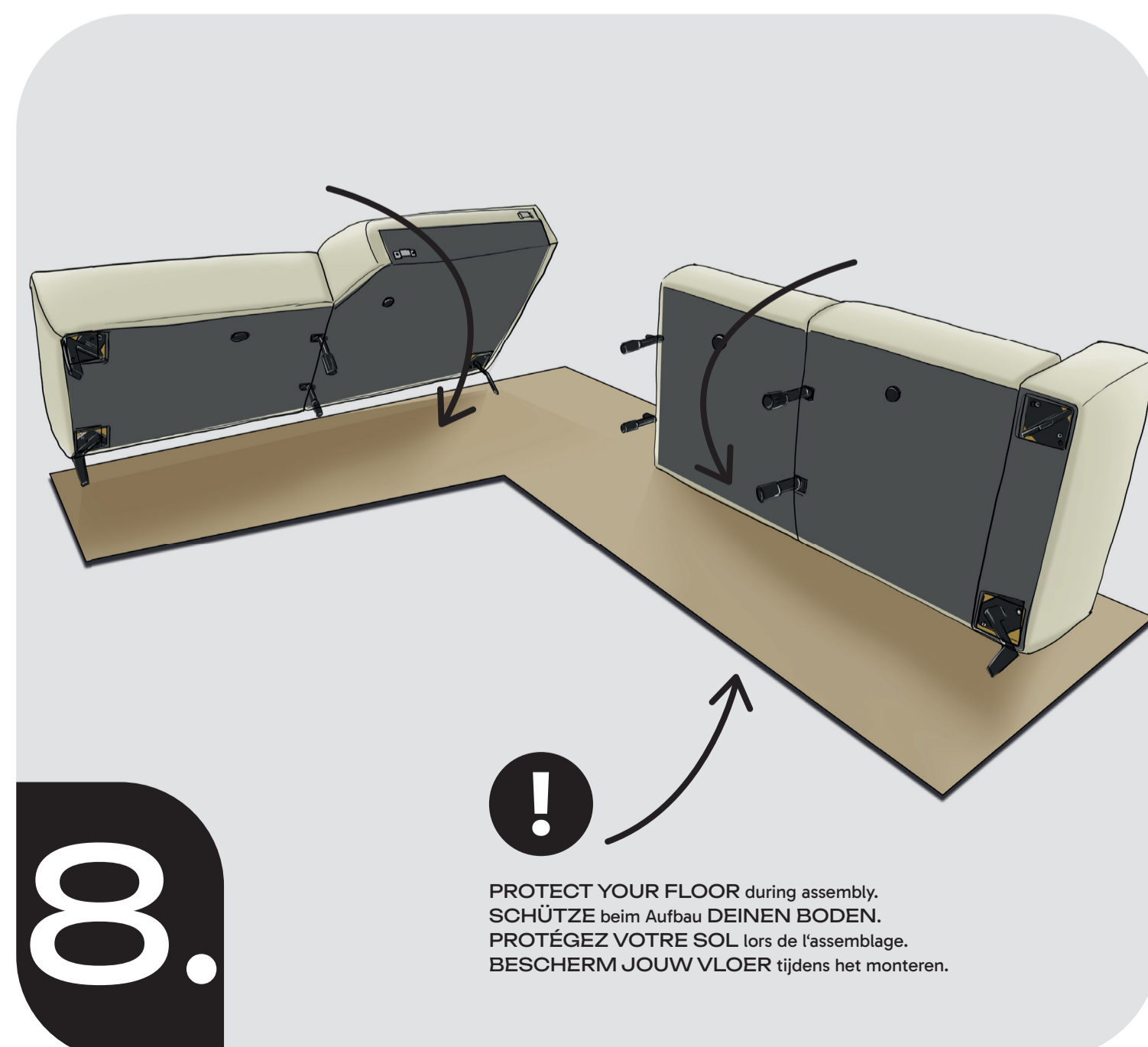
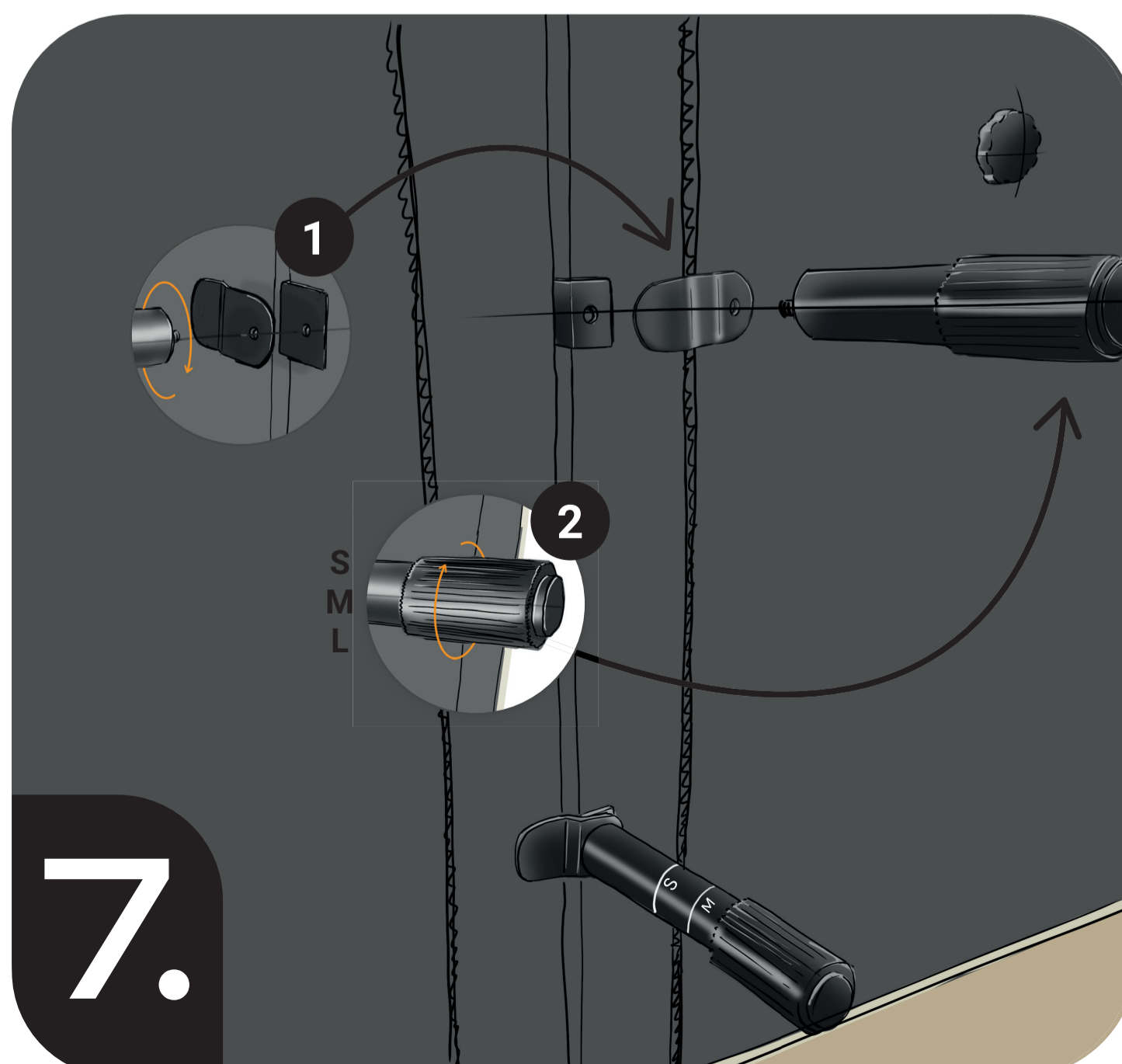
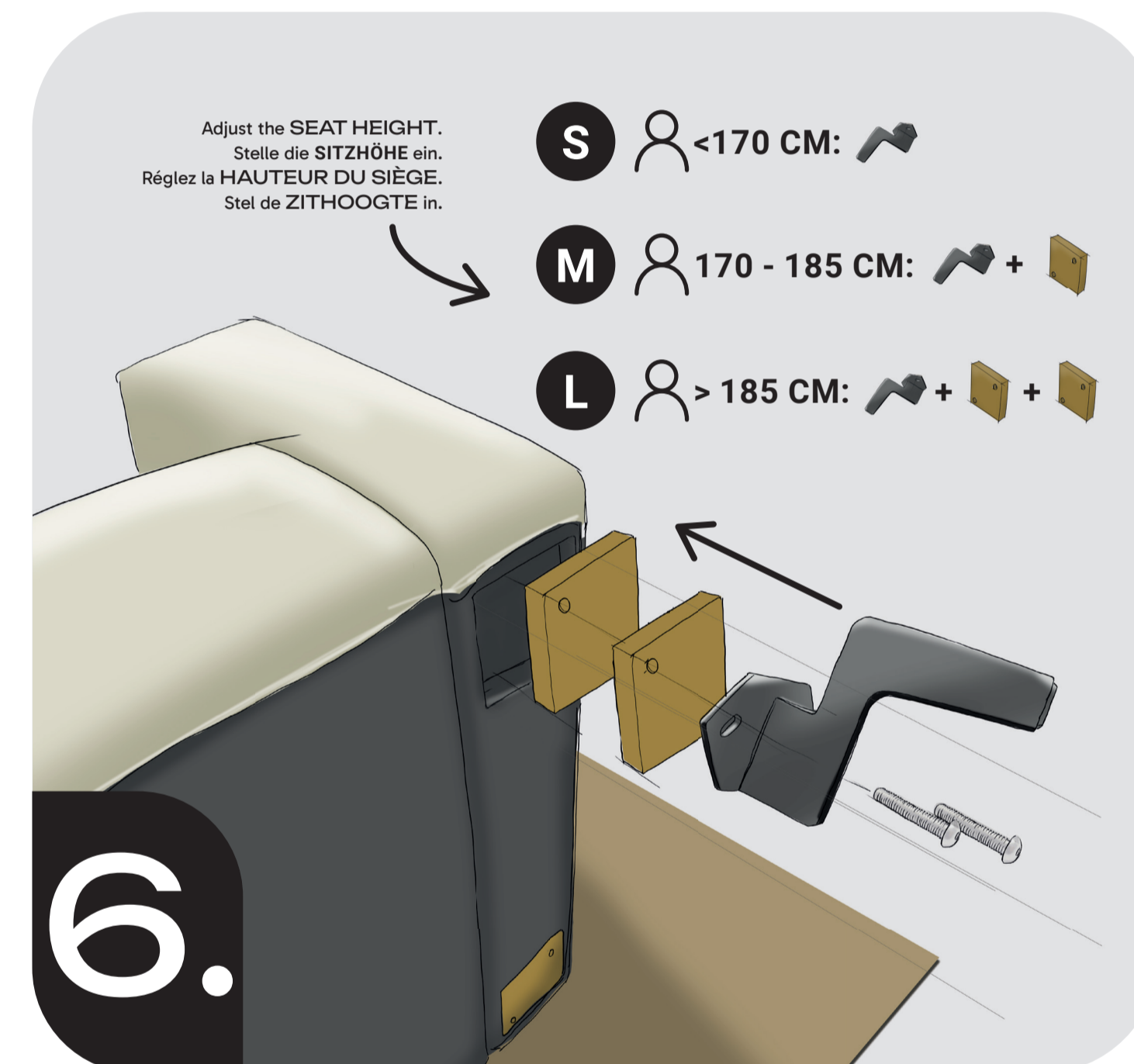
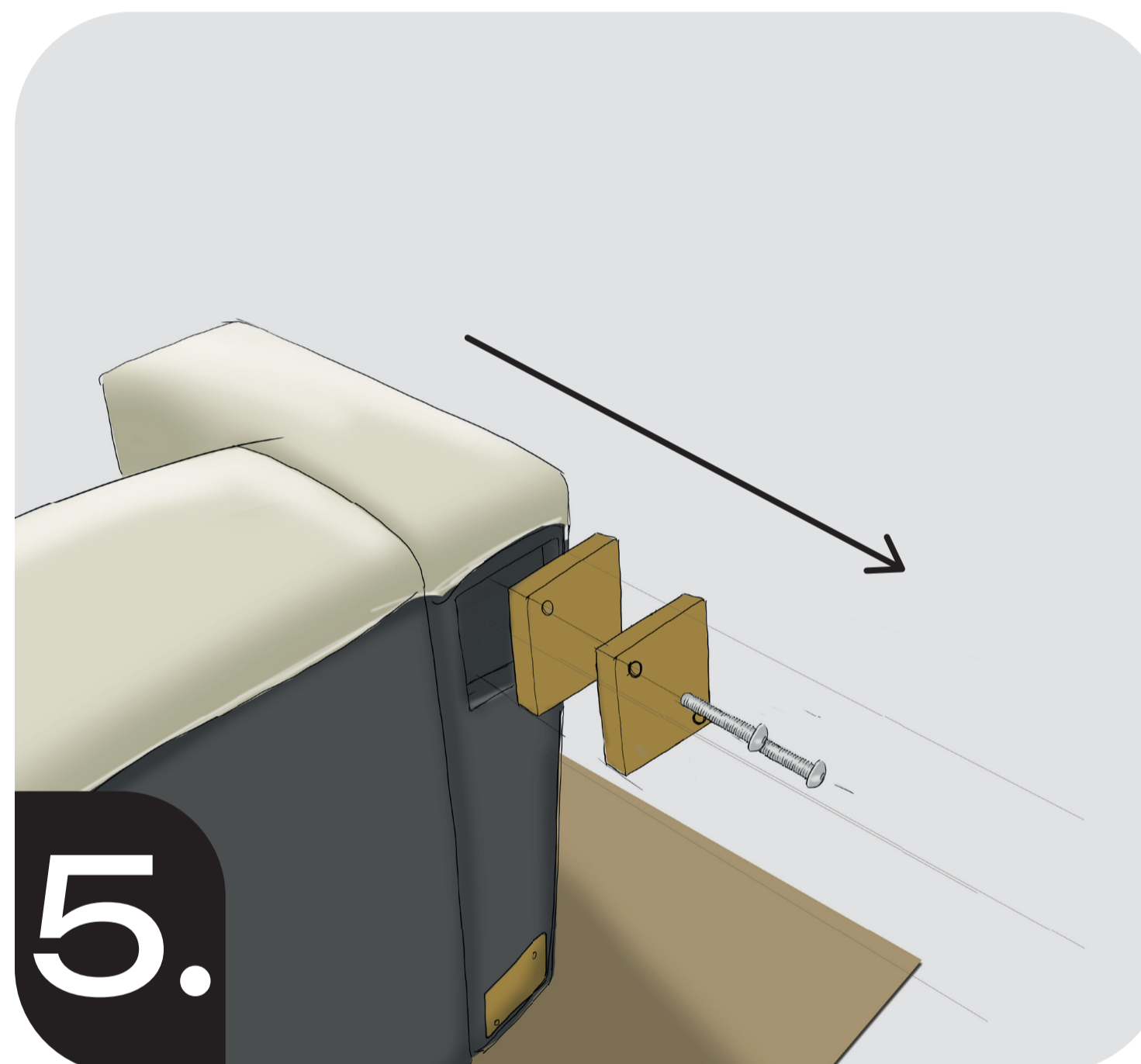
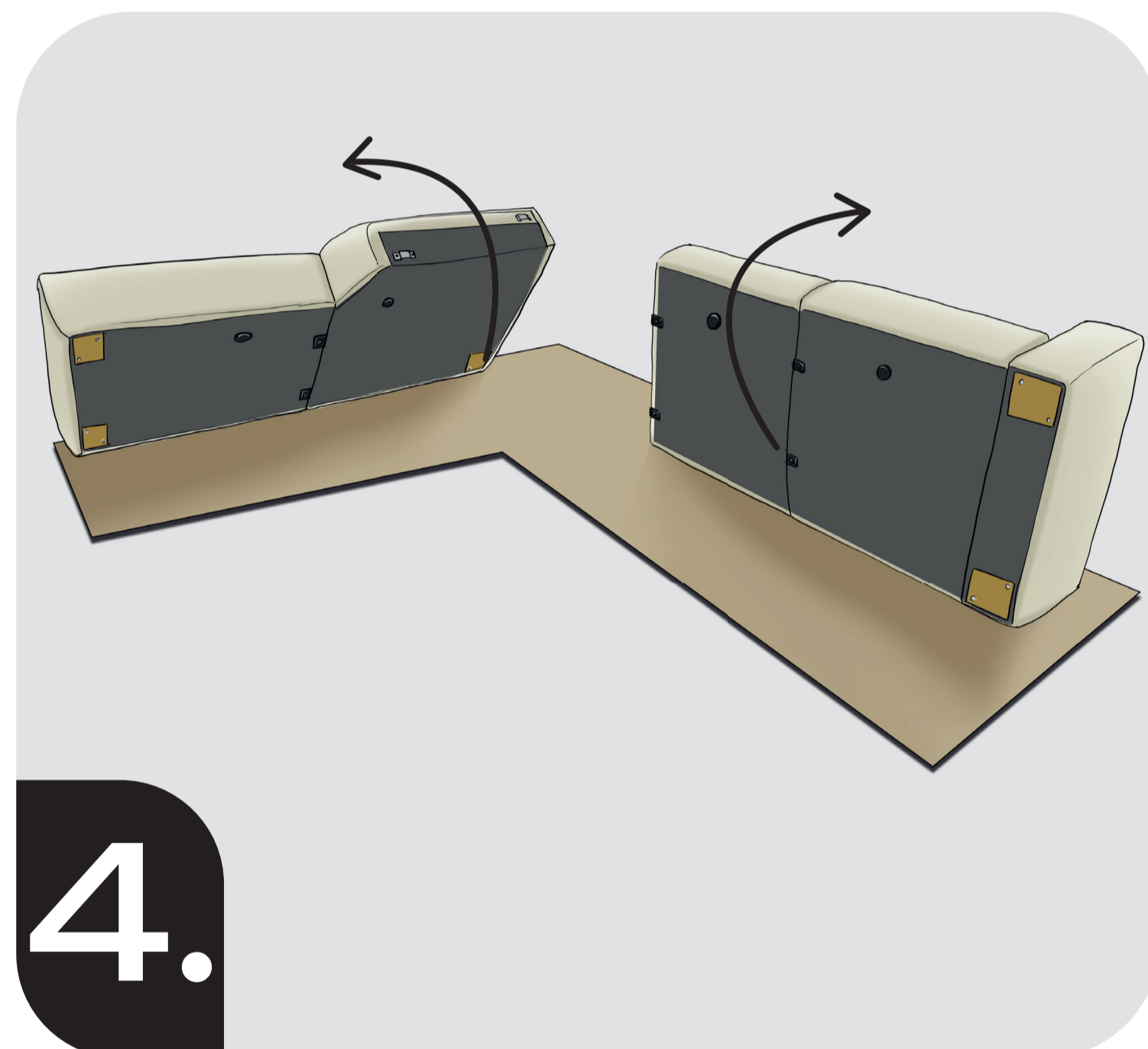
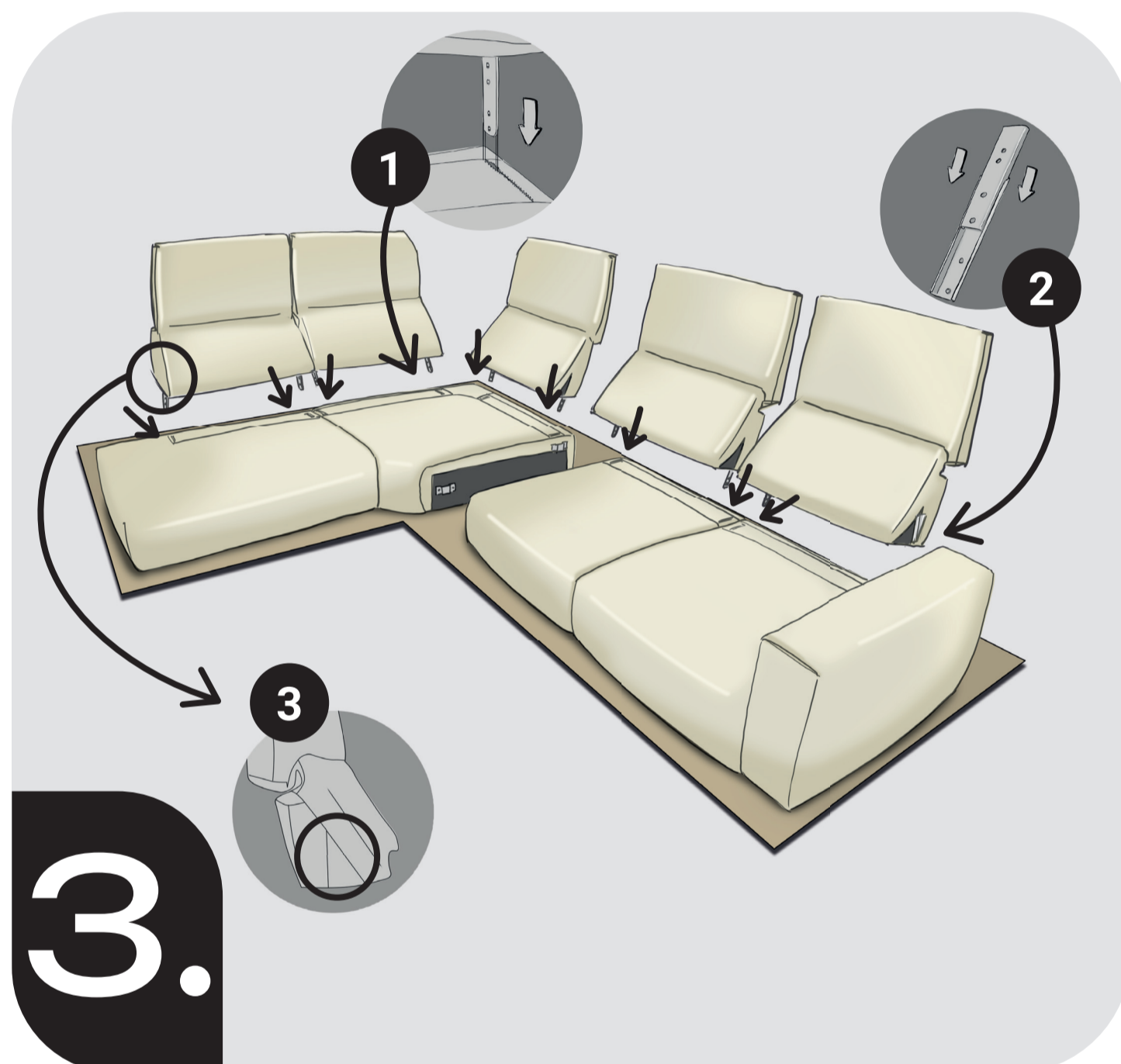
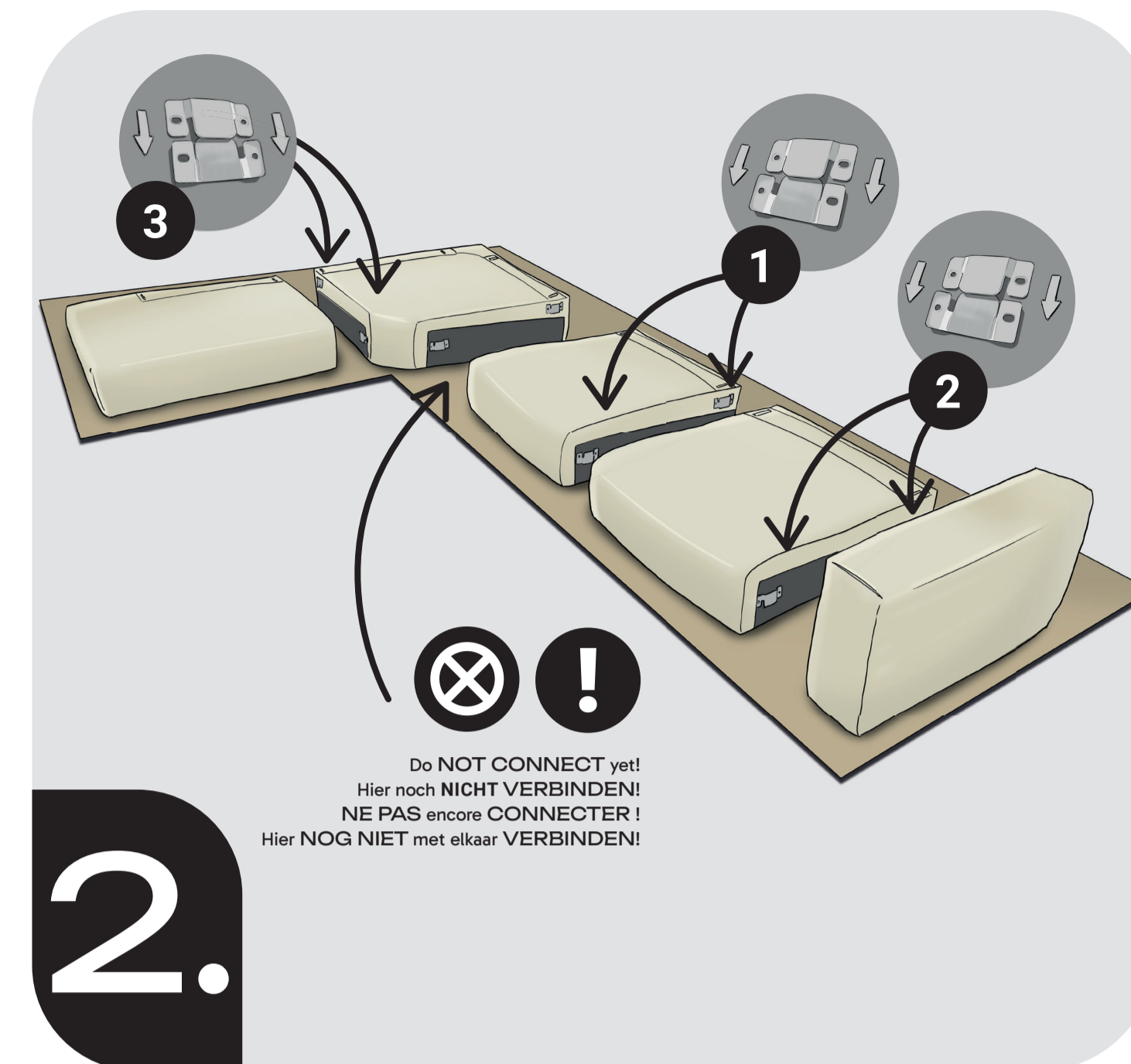
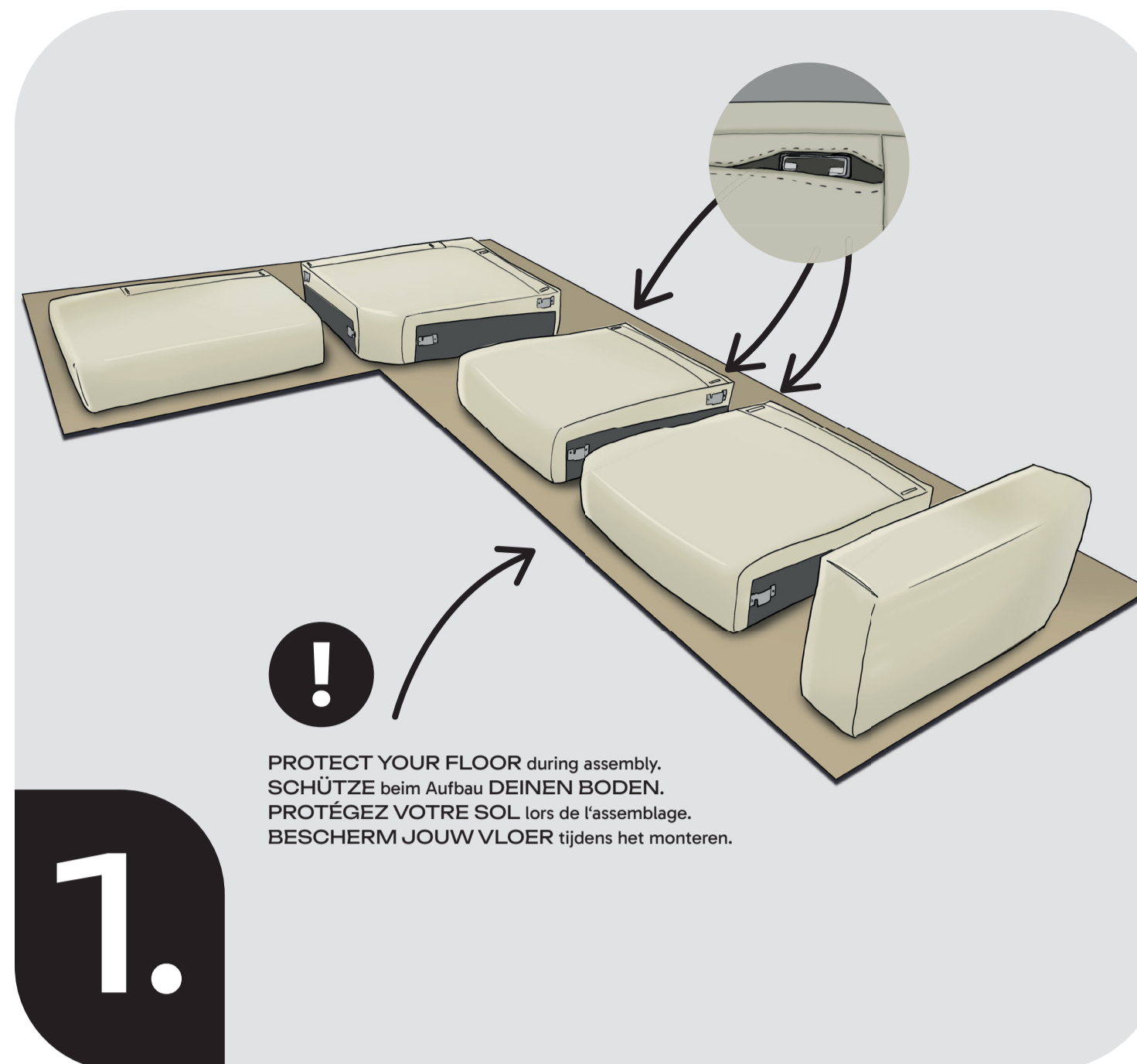
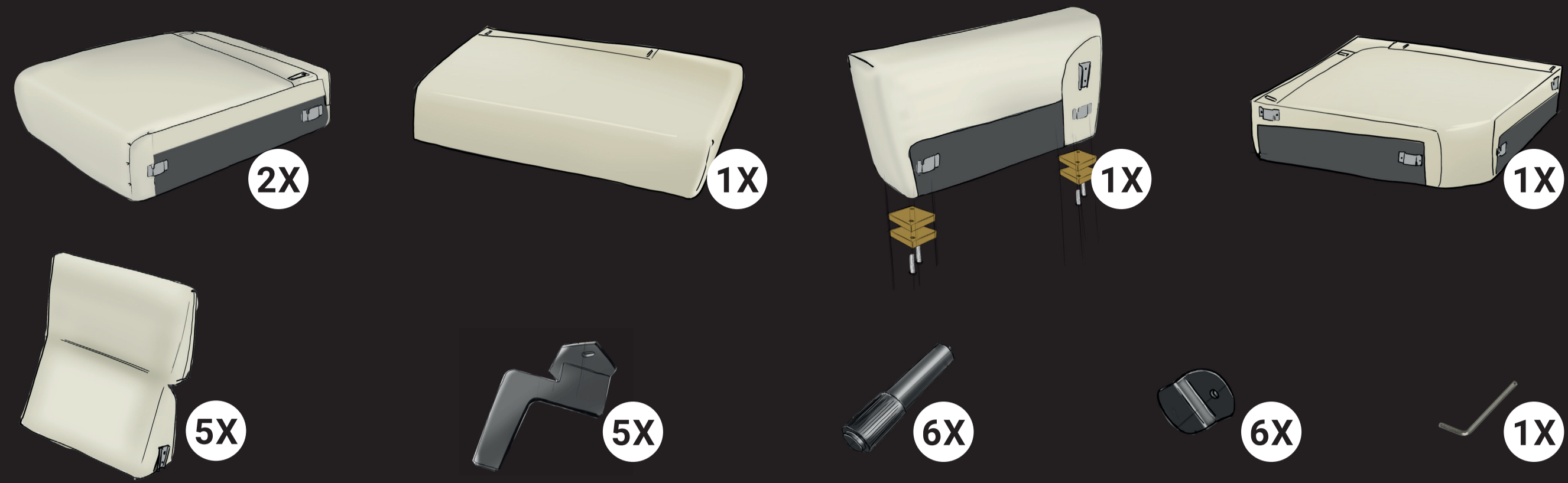

Content

Inhalt
Contenu
Inhoud

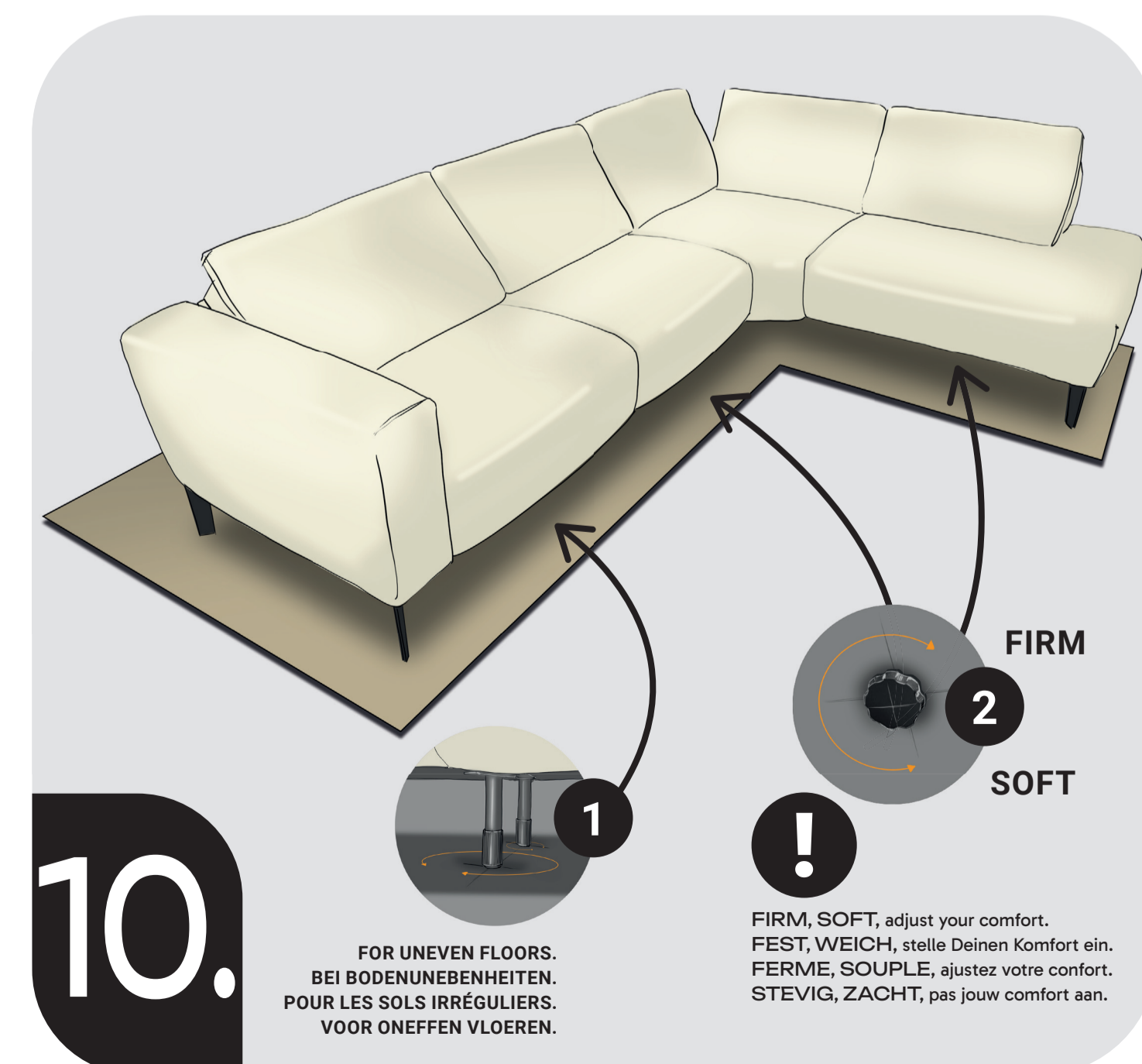
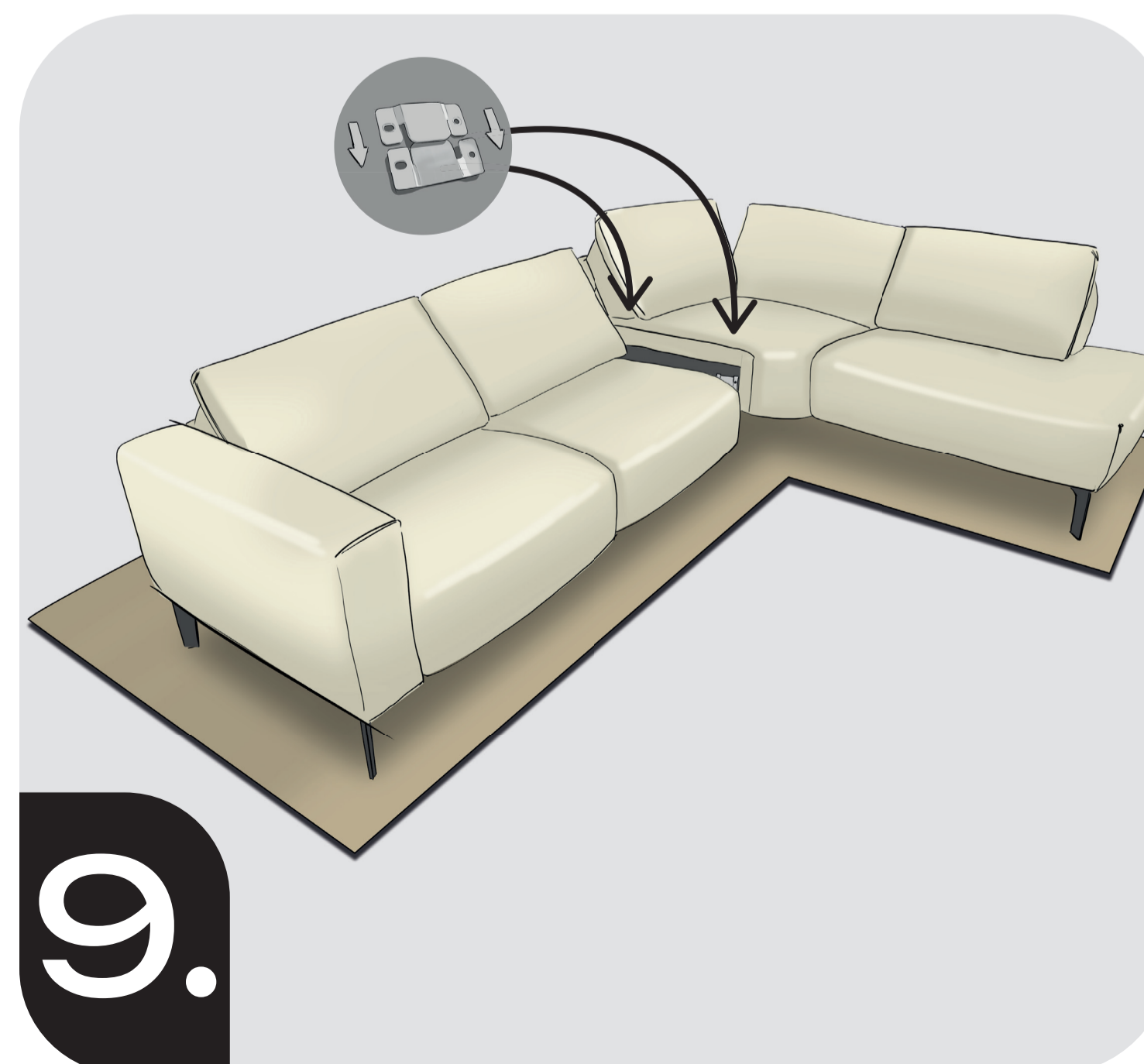
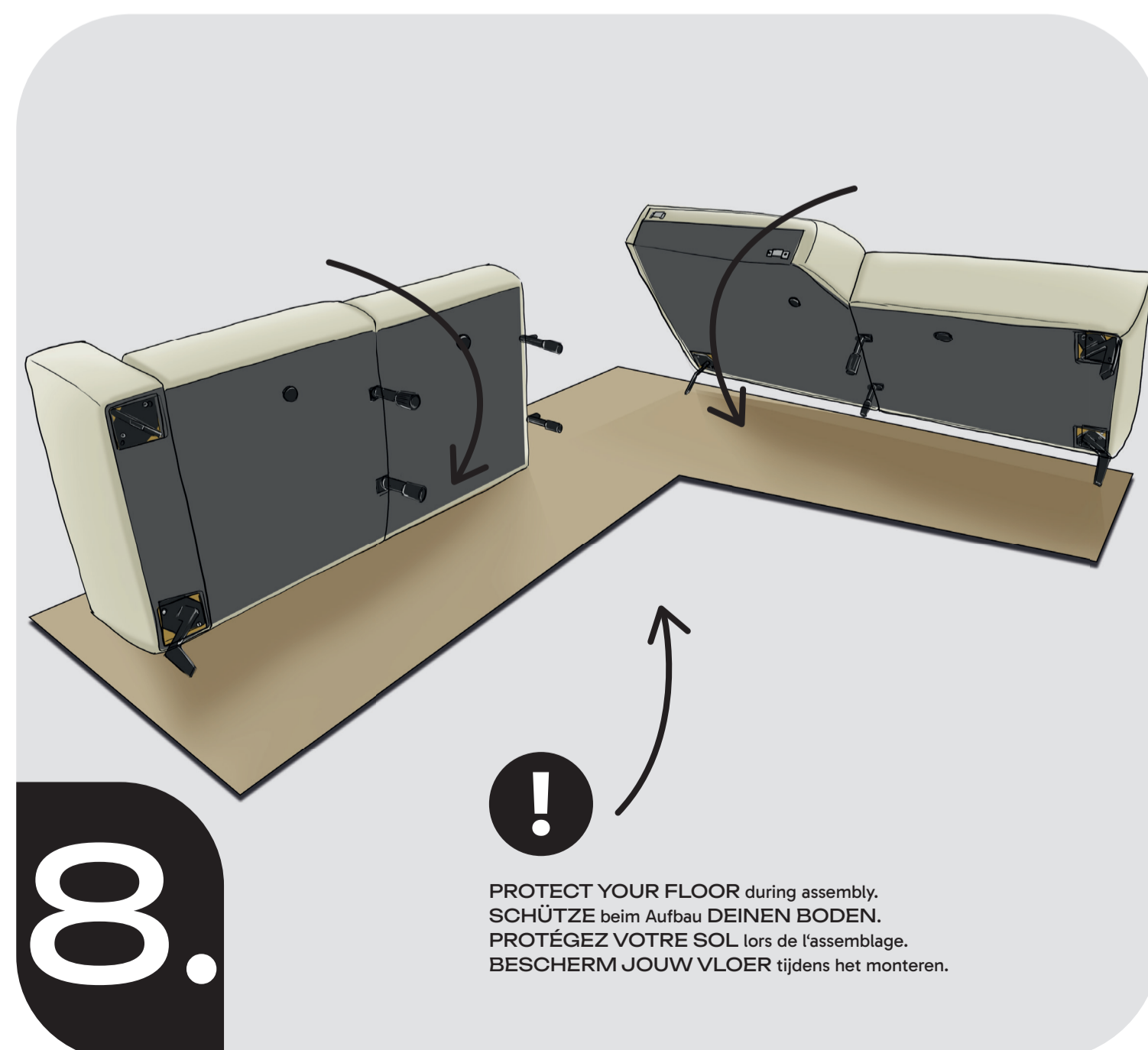
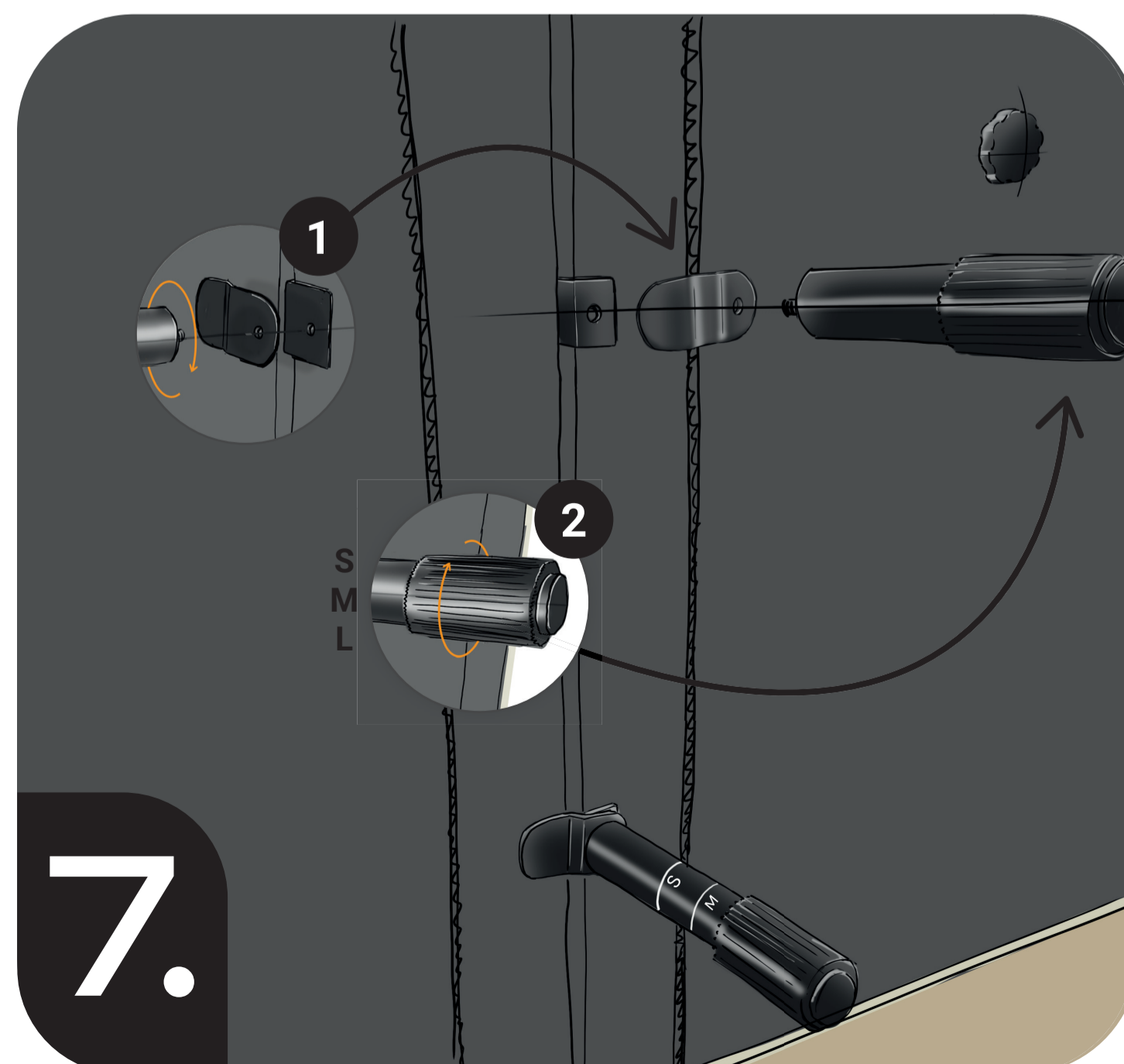
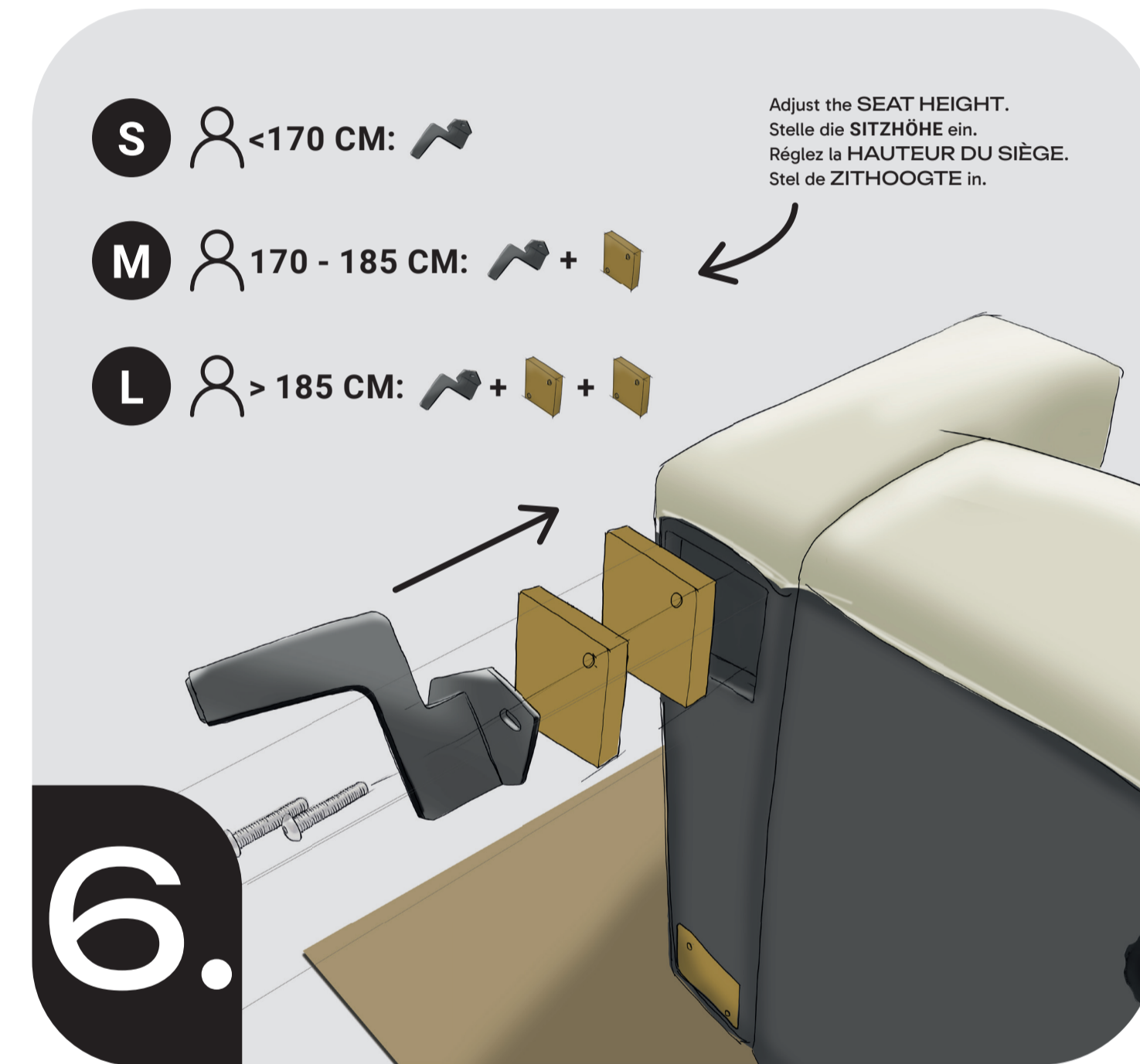
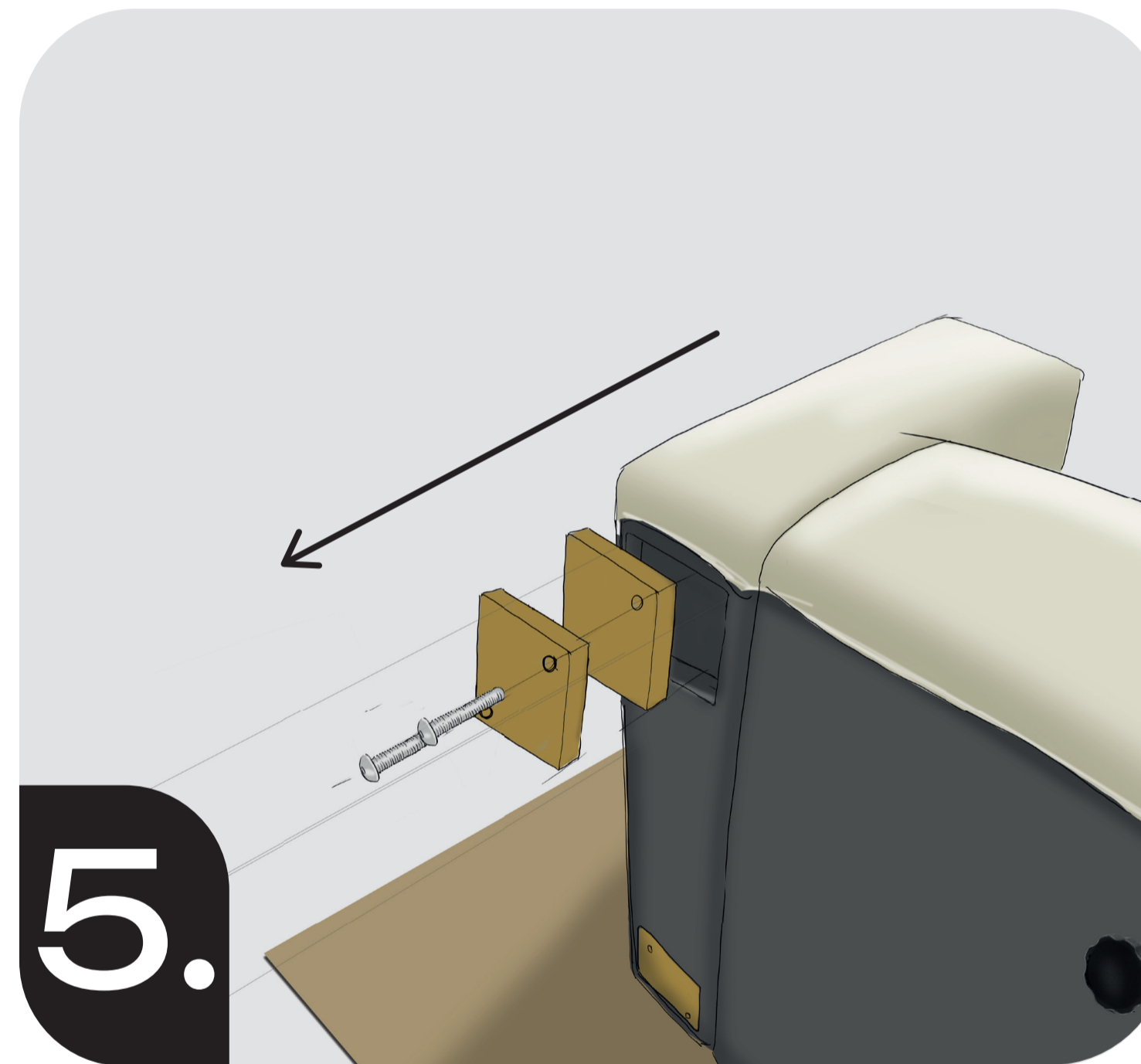
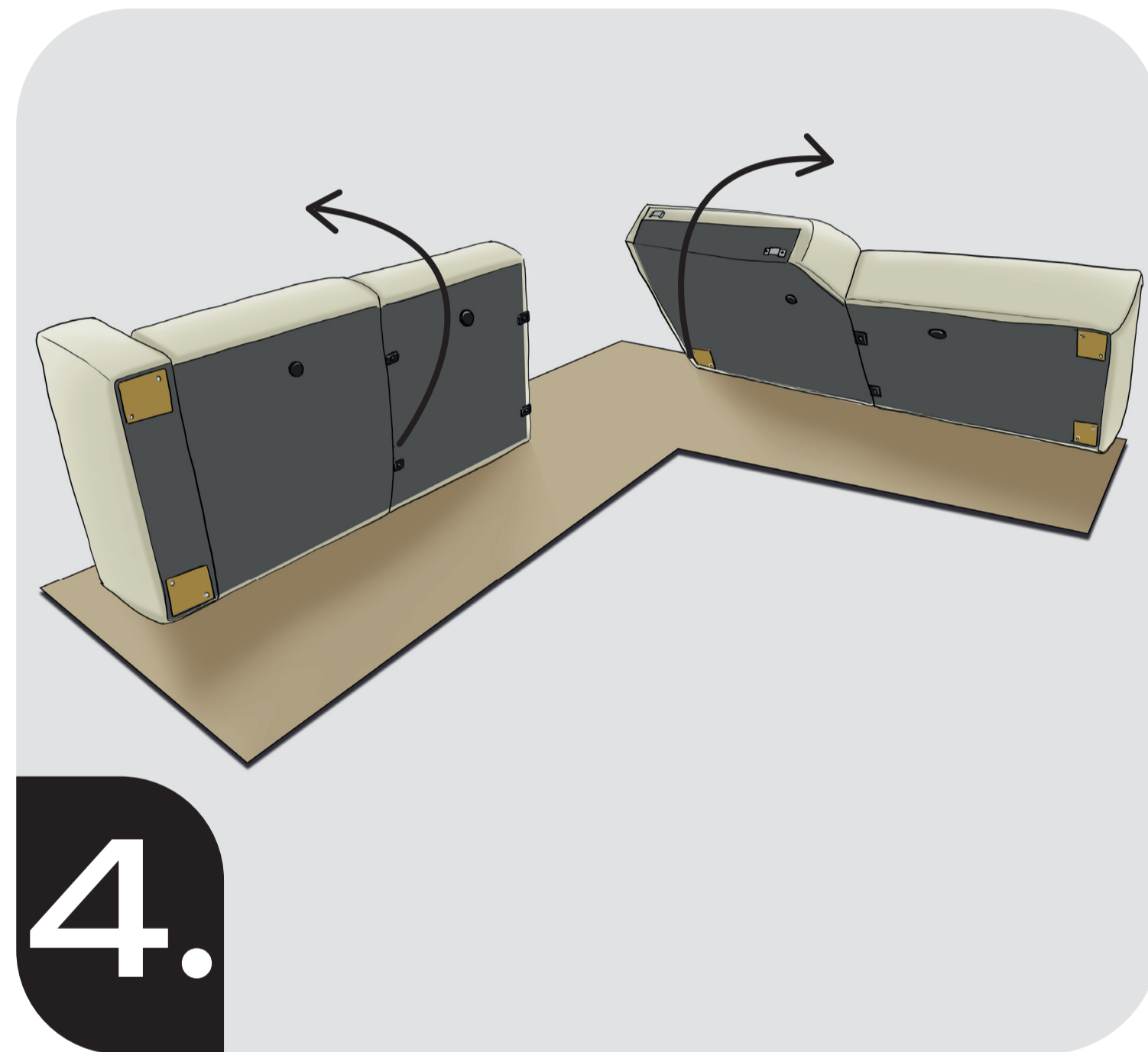
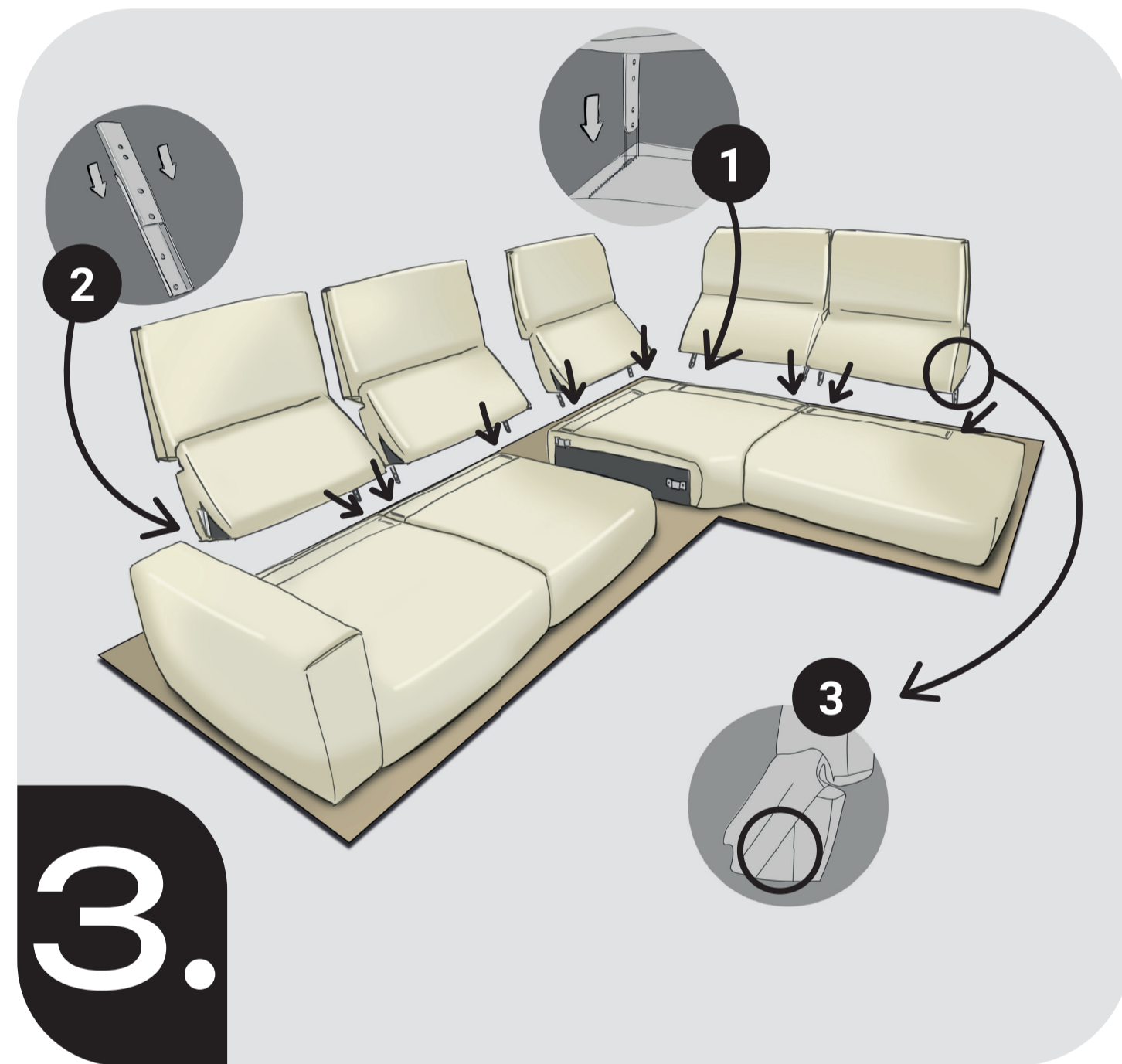
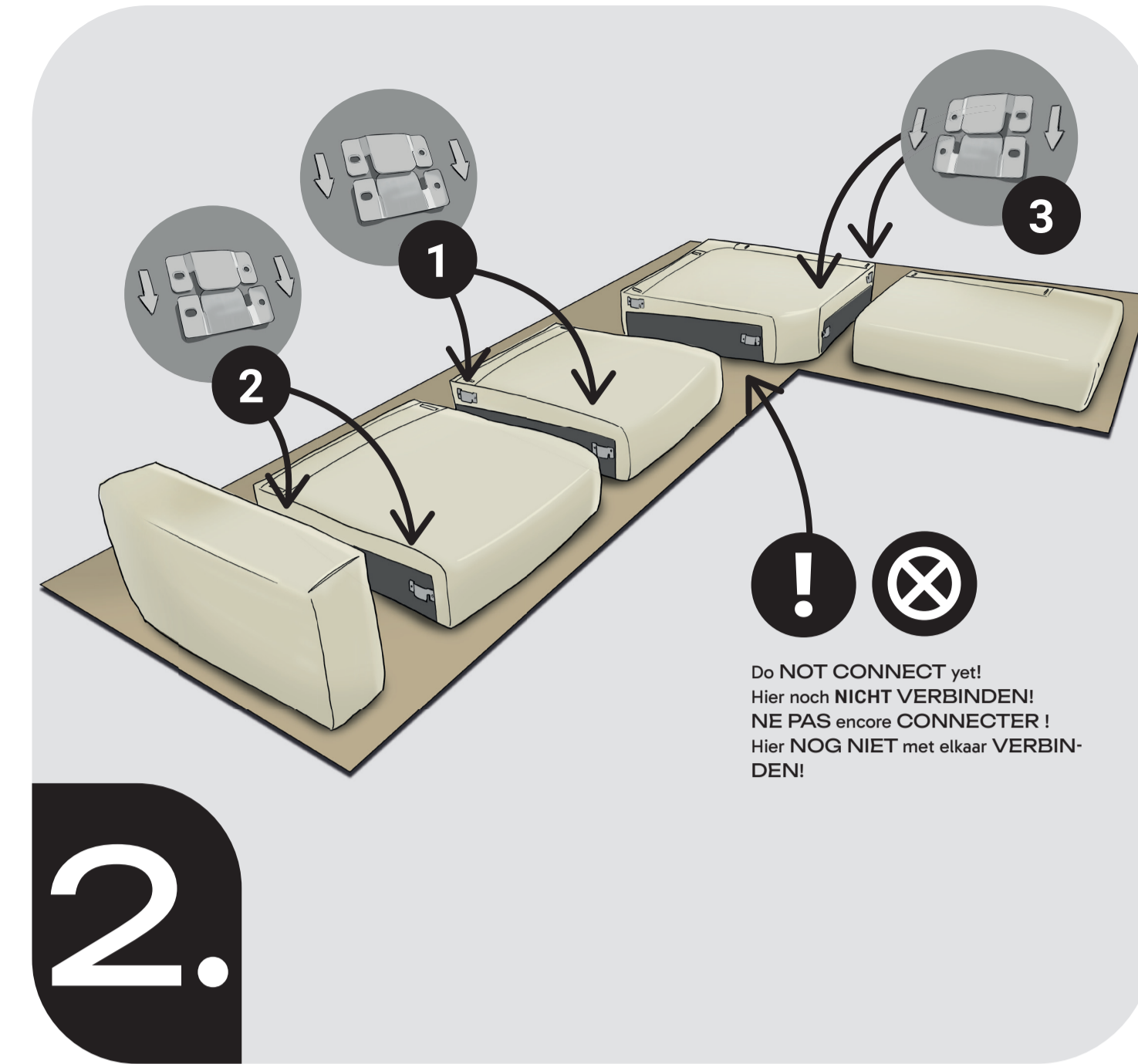
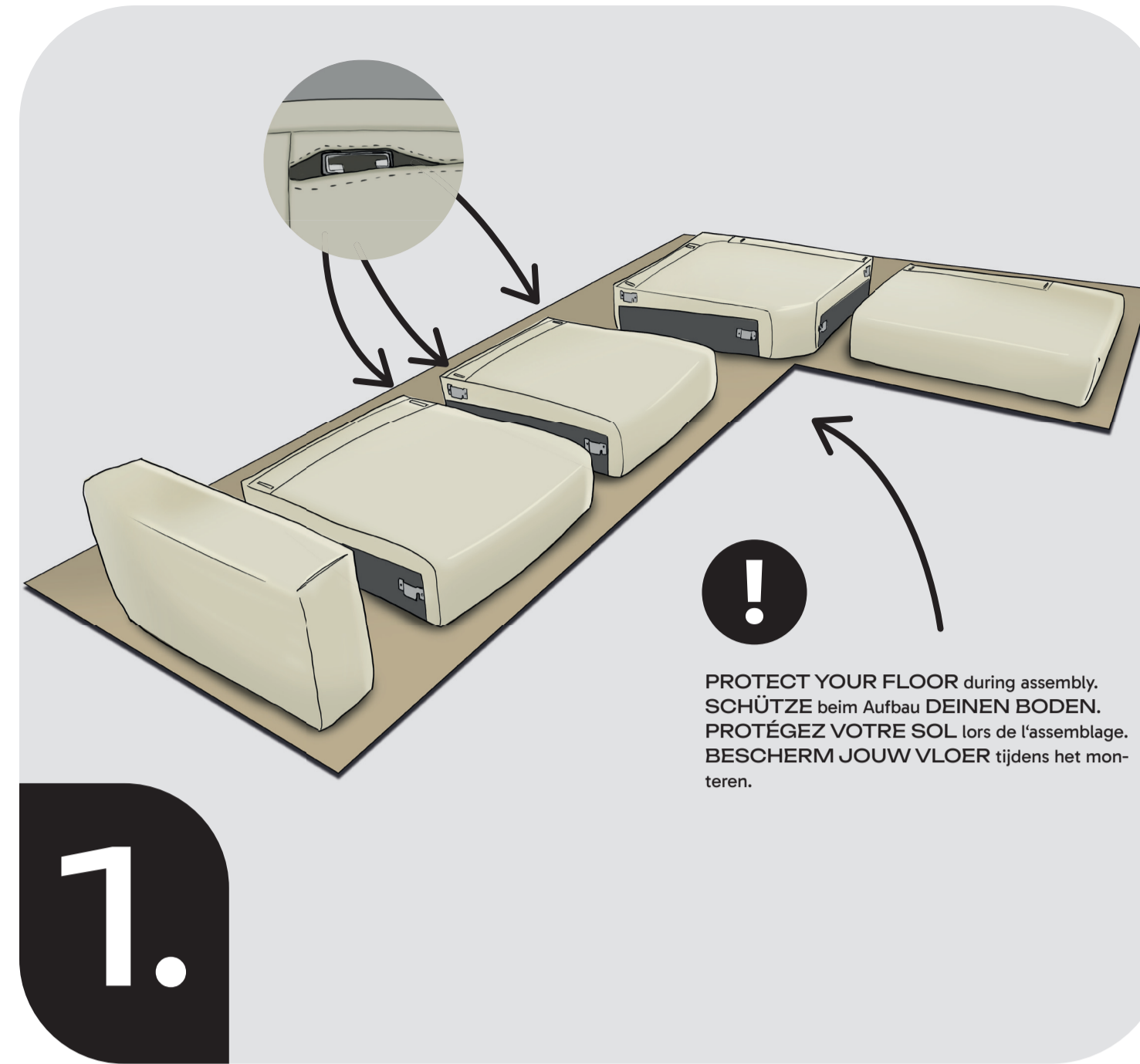

Dear customer,

It means a lot to us that you have chosen us. We would like to thank you for that. Your sofa was developed and produced by us with passion and love. We wish you many great moments with it.

Lieber Kunde,

es bedeutet uns viel, dass Du Dich für uns entschieden hast. Dafür bedanken wir uns. Dein Sofa wurde von uns mit viel Leidenschaft und Liebe entwickelt und produziert. Damit wünschen wir Dir viele tolle Momente.

Cher client,

Le fait que vous nous avez choisis est très important pour nous. Nous tenons à vous en remercier. Votre canapé a été développé et produit par nous avec beaucoup de passion et d'amour. Nous vous souhaitons de passer de bons moments avec lui.

Beste klant,

Het betekent veel voor ons dat je voor ons gekozen heeft. Wij willen jij daarvoor bedanken. Jouw sofa is door ons met veel passie en liefde ontwikkeld en geproduceerd. Wij wensen je er veel mooie momenten mee.

Marek MUSIALSKI
Quality director

Stephan ROM
Administrator

Tel. +32 87 59 59 08 / +49 241 95 50 90 02 (DE) E-Mail: info@sensoo.com

sensoo.com

Q sensoo